

LUG BUTTERFLY VALVE



OUR STANDARD
YOUR GUARANTEE

- ISO 9001 Quality
- ISO 14001 Environment
- OHSAS 18001 Health & Safety





LUG BUTTERFLY VALVE

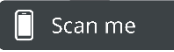

DESCRIPTION

Lug butterfly valves with epoxy coated ductile iron body are designed to control various media in commercial and industrial applications. Valve mount standard is DIN PN 16. Seat to flange seal, eliminates the need for flange gaskets. Disc is precision machined 1.4408 (CF8M) . Two piece stem and disc design enhances the flow capacity and reduces turbulence.

FEATURES

- ISO5211 top mounting for manual, air or electric actuators
- Unique wave line seat reduces torque and extends seal life
- Ductile iron body with 3-layer epoxy coating
- 316SS disc with 2-piece stem design enhances flow capacity
- EPDM, NBR (Buna-N), or FPM (Viton) seal options
- O-ring stem/shaft seals, same material as seat
- PTFE graphite reinforced stem bearings
- Pressure rated 230 PSI (16 Bar)
- Optional 10 positional locking hand lever

APPLICATION

Lug body butterfly valves are used to control the flow of water, oils, air, vacuum and other media compatible with the materials of construction. Valves can be operated with manual, air or electric actuators.

Four seal options are available :

EPDM , NBR (Buna-N), FPM, PTFE, VMQ

OPERATION

Direct mount lug butterfly valves can be easily fitted with optional manual operator, air actuator or electric actuator using the standard ISO5211 top mounting. Turning the square stem one quarter turn rotates the stainless steel disc and opens or closes the valve. Unique wave line soft seat reduces the torque required to close the valve and extends the seal life.

TEMPERATURE RANGE

EPDM: -20 to 120°C , **NBR(Buna-N):** -15 to 85°C , **FKM:** -15 to 180°C , **VMQ:**-30 to 200°C , **PTFE:**-20 to 200°C

OPTIONS

- Hand lever with 10 position locking
- Gear Box
- Air Actuators
- Electric Actuators

CONSTRUCTION

VALVE BODY	Epoxy Coated Ductile Iron GGG40
DISC	1.4408 Stainless Steel (CF8M) , Aluminum Bronze (C954)
DISC SEAT OPTIONS	EPDM, NBR (Buna-N) , FKM , VMQ , PTFE
STEM SEALS	O-ring (Same Material As Seat)
STEM	420SS
BEARINGS	PTFE Graphite Reinforced
FASTENERS	Stainless Steel

SPECIFICATIONS

DIM	KV-VALUE RATED FLOW COEFFICIENT (M ³ /H AT 1 BAR ΔP)									
[MM]	MAX TORQUE [NM]	10°	20°	30°	40°	50°	60°	70°	80°	90°
DN50	12	<1	<1	5	14	29	47	71	98	107
DN65	17	1	2	11	27	50	77	122	171	213
DN80	24	3	6	28	54	91	140	213	301	404
DN100	35	5	14	57	108	175	262	404	594	799
DN125	59	6	27	84	156	248	385	624	954	1239
DN150	84	7	51	129	224	363	572	977	1535	1929
DN200	164	22	114	229	401	639	1018	1755	2880	3484
DN250	280	33	171	334	634	970	1530	2650	4403	5753
DN300	386	49	250	490	925	1416	2231	3865	6641	8828
DN350	700	118	301	631	1131	1918	3081	4963	8884	10308
DN400	850	153	393	824	1478	2506	4024	6482	11603	13464
DN450	1497	195	498	1043	1871	3170	5093	8210	14686	17041
DN500	1988	240	615	1288	2309	3913	6287	10128	18130	21038
DN600	3264	345	885	1853	3326	5635	9054	14584	26109	30295

Above mentioned torques are based on on/off services/lubricating liquid.

VALVE SIZING

Determining the size of butterfly valves for control purposes should not be done on the basis of the nominal diameter of the pipe but should be calculated on the basis of the operating characteristics in order to attain the correct control characteristics.

Convalve Lug Butterfly valves are designed with approximately equal percentage characteristics over an opening angle of 65°. You only need to consider the opening angle when determining the size of control valves. When determining the valve nominal diameter calculate the Kv value from the below

Liquid:

$$K_v = Q \times \sqrt{\frac{w}{\Delta S}}$$

Gas:

$$K_v = \frac{V_N}{514} \sqrt{\frac{G \times T}{\Delta S \cdot P_d}}$$

KV = Flow coefficient
 Q = Max. flow volume in m³/h
 w = Exact weight in kg/m³
 ΔS = Pressure drop in bar
 VN = Max. flow in Nm³/h
 G = Exact weight in kg/Nm³
 T = Absolute temp. in ° Kelvin
 Pd = Absolute pressure downstream in bar

Example: DN 100

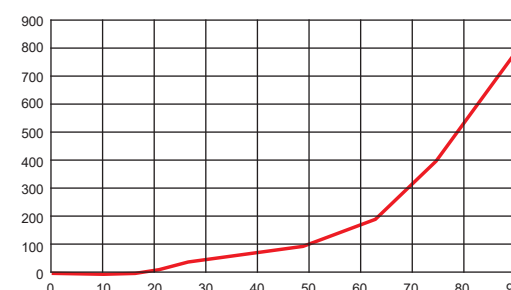

PRODUCT DATA SHEET

VALVE STRUCTURE: HARD SEAL 50-150

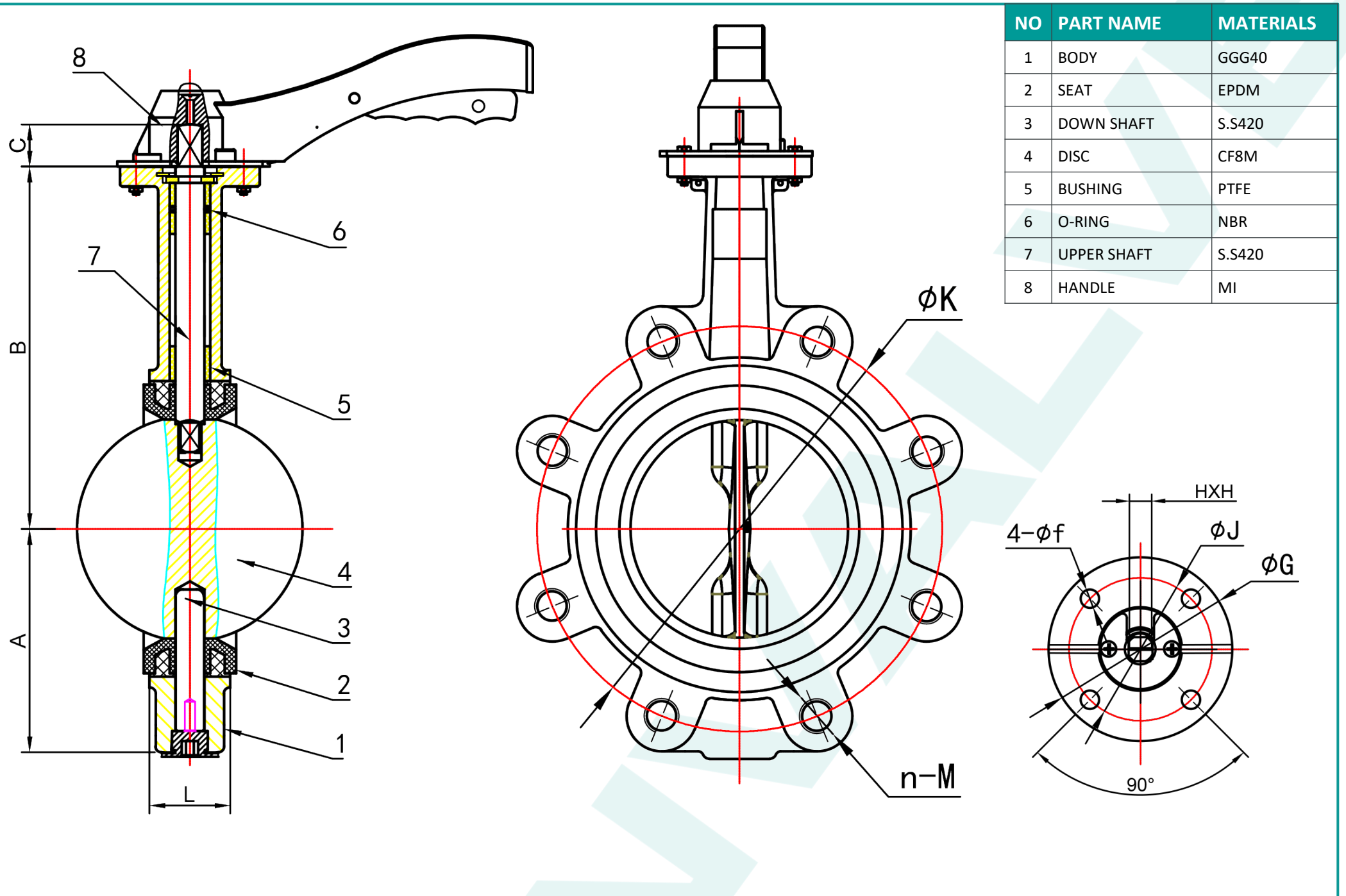

NO	PART NAME	MATERIALS
1	BODY	GGG40
2	SEAT	EPDM
3	DOWN SHAFT	S.S420
4	DISC	CF8M
5	BUSHING	PTFE
6	O-RING	NBR
7	UPPER SHAFT	S.S420
8	HANDLE	MI

DN	INCH	A	B	C	L	PN10		PN16		ANSI 125/150		ΦG	ΦJ	4-Φf	HXH
						ΦK	N-M	ΦK	N-M	ΦK	N-M				
40	1.5"	61	130	14	33	110	4-M16	110	4-M16	98	4-1/2"-12	65	50	4-07	9X9
50	2"	77	136	14	43	125	4-M16	125	4-M16	121	4-5/8"-11	65	50	4-07	9X9
65	2.5"	88	142	14	46	145	4-M16	145	4-M16	140	4-5/8"-11	65	50	4-07	9X9
80	3"	95	158	15	46	160	8-M16	160	8-M16	152	4-5/8"-11	65	50	4-07	9X9
100	4"	107	182	17	52	180	8-M16	180	8-M16	191	8-5/8"-11	90	70	4-010	11X11
125	5"	121	194	17	56	210	8-M16	210	8-M16	216	8-3/4"-10	90	70	4-010	14X14
150	6"	144	217	17	56	240	8-M20	240	8-M20	241	8-3/4"-10	90	70	4-010	14X14

VALVE STRUCTURE: HARD SEAL 200-300

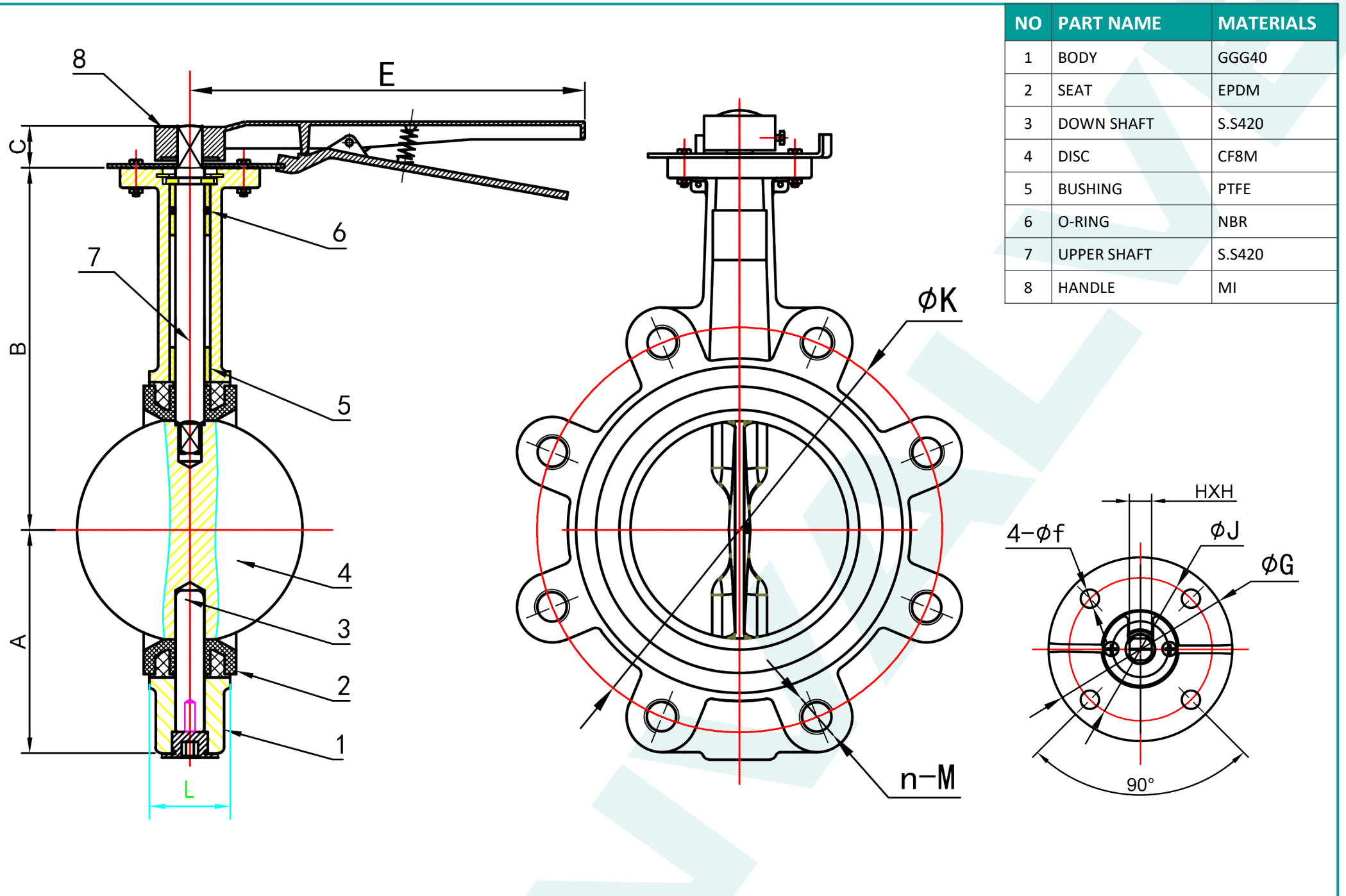

NO	PART NAME	MATERIALS
1	BODY	GGG40
2	SEAT	EPDM
3	DOWN SHAFT	S.S420
4	DISC	CF8M
5	BUSHING	PTFE
6	O-RING	NBR
7	UPPER SHAFT	S.S420
8	HANDLE	MI

DN	INCH	A	B	C	L	E	PN10		PN16		ANSI 125/150		ΦG	ΦJ	4-Φf	HXH
							ΦK	N-M	ΦK	N-M	ΦK	N-M				
200	8"	171	243	30	60	358	295	8-M20	295	12-M20	299	8-3/4"-10	125	102	4-012	17X17
250	10"	205	280	39	68	358	350	12-M20	355	12-M24	362	12-7/8"-9	125	102	4-012	22X22
300	12"	235	310	39	78	358	400	12-M20	410	12-M24	432	12-7/8"-9	125	102	4-012	22X22